

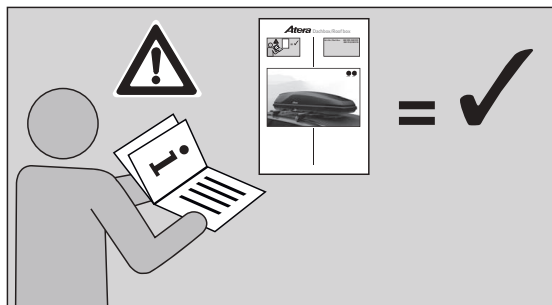

Atera TENTINO



Art.-Nr. / Part-No.:

082 299



Atera TENTINO

Accessories at a glance
Zubehör auf einen Blick
Les accessoires en un coup d'œil



General notes
Allgemeine Hinweise
Notes générales



Unpacking
Auspacken und entnehmen aller Komponenten
Déballage



Assembly of the ladder
Montage der Leiter
Visser l'échelle



Tarpaulin, fixing the roof sheet
Abdeckplane am Dachzelt fixieren
Bâche, fixation de la tôle du toit



Assembly tent on roof rack
Montage Dachzelt auf Reling / Dachträger
Montage de la tente sur la galerie de toit



Setting up first time after mounting
Der erste Aufbau nach erfolgreicher Montage
Première mise en place après le montage



Telescopic ladder for adjustment and entry
Teleskopleiter, Ausklapp- und Einstieghilfe
Échelle télescopique pour le réglage et l'entrée



Care instructions
Pfleghinweise
Instructions d'entretien



Storage
Lagerung
Stockage



Safety instructions
Sicherheitshinweise
Consignes de sécurité

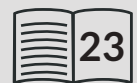



Atera TENTINO

Accessoires at a glance
Zubehör auf einen Blick
Les accessoires en un coup d'œil

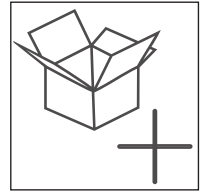

Set A
4x

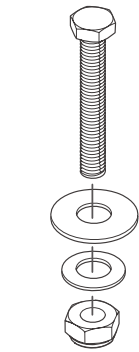

M8

2x

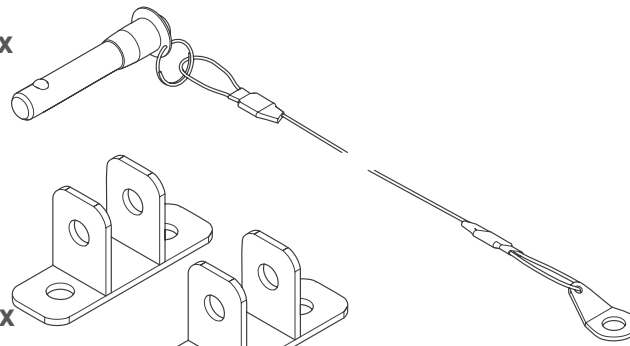

2x

4x

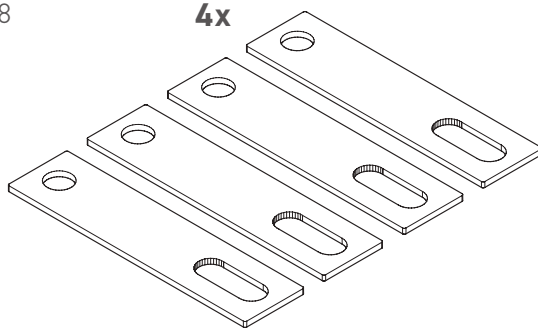

1x

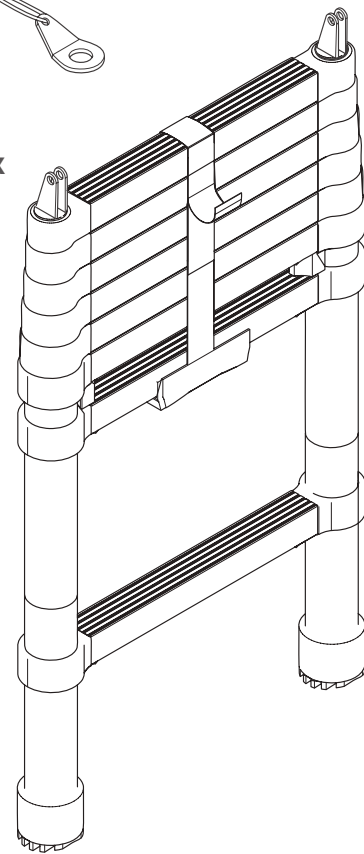

Set B
8x

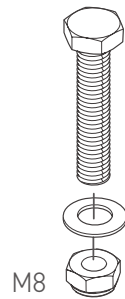

M8

8x

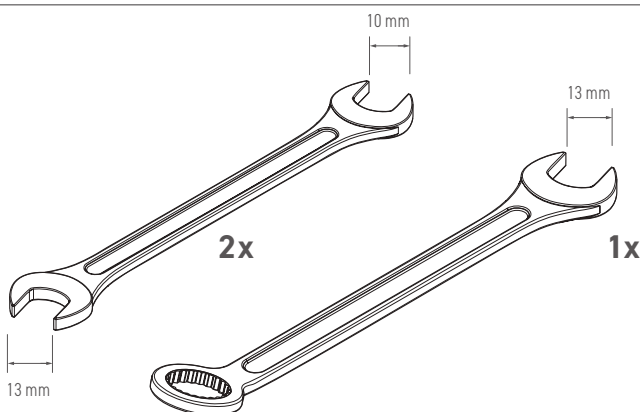
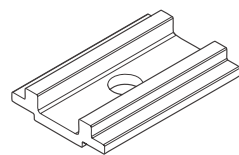

2x

1x

13 mm

10 mm

13 mm





Atera TENTINO

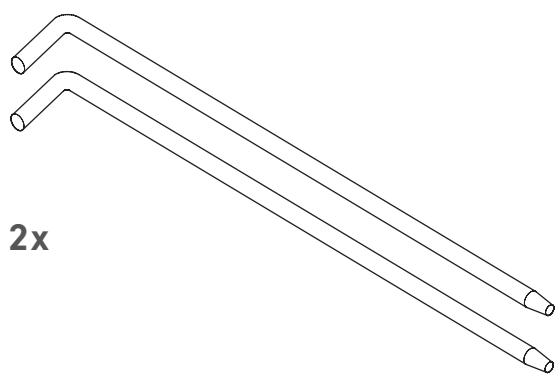

2x



1x

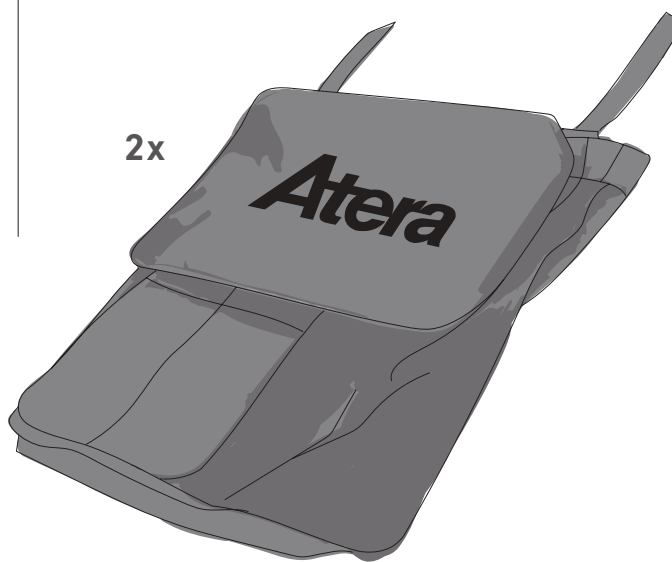

2x





Atera TENTINO

General notes
Allgemeine Hinweise
Notes générales

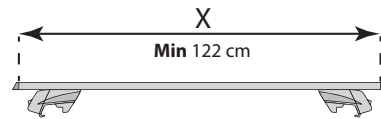
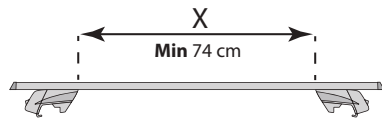

Max 130 km/h



Max
136 kg

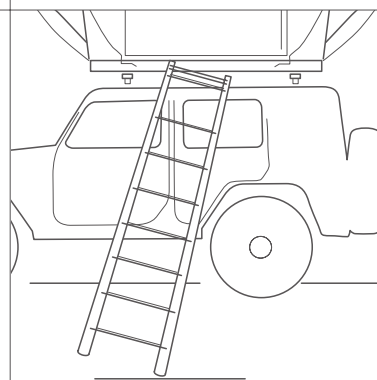
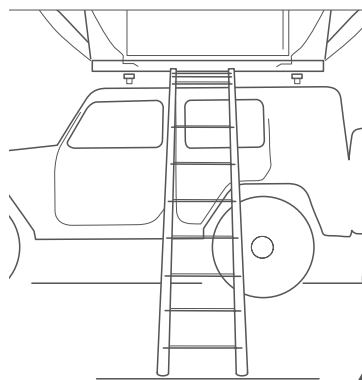
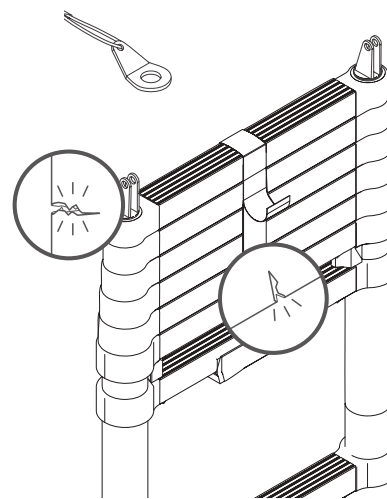
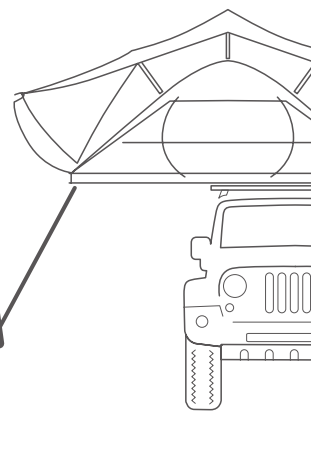



Atera TENTINO

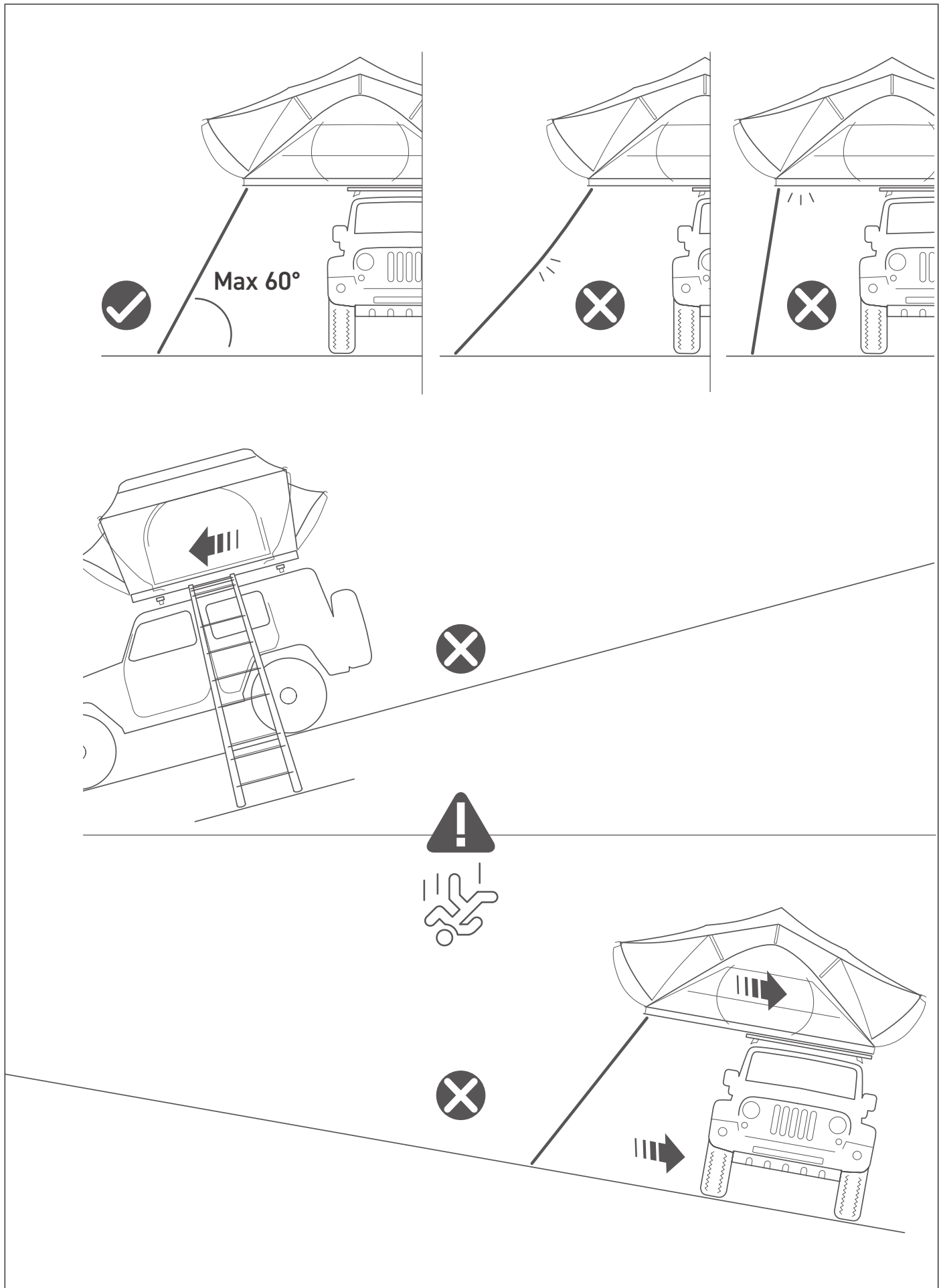



Atera TENTINO



Max 60 °C

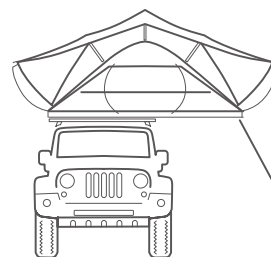
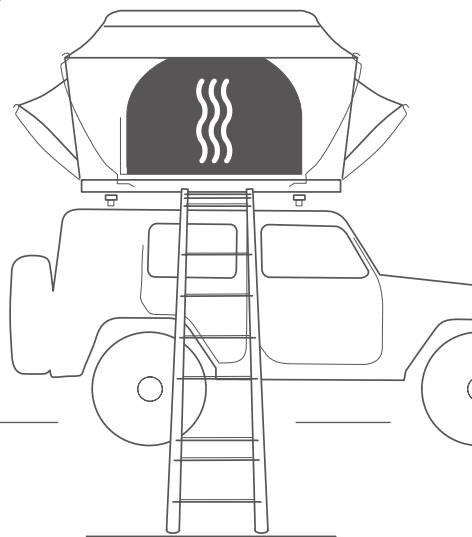



Atera TENTINO

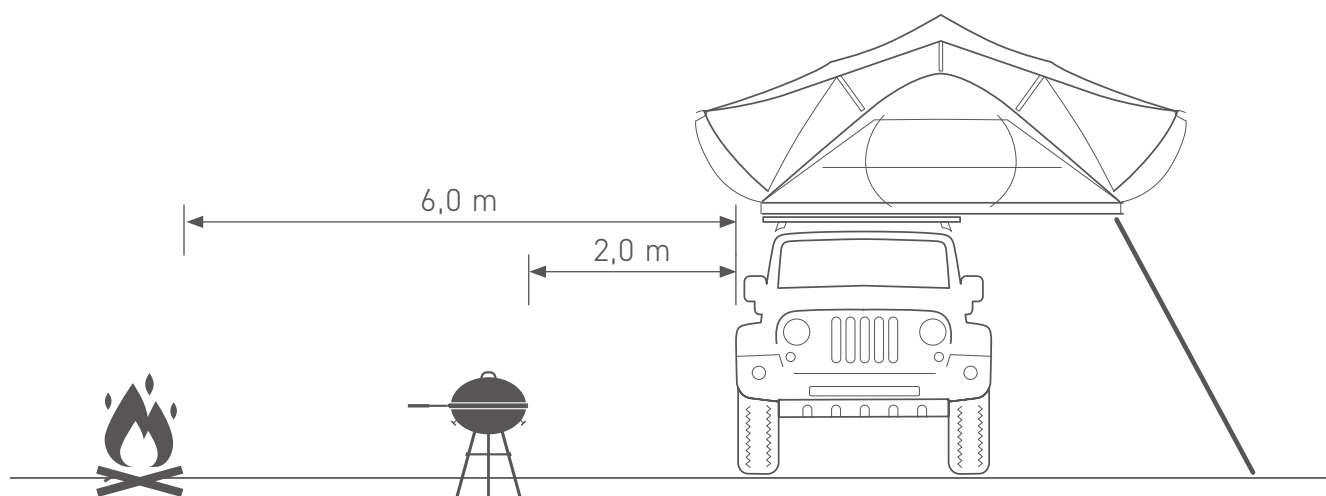
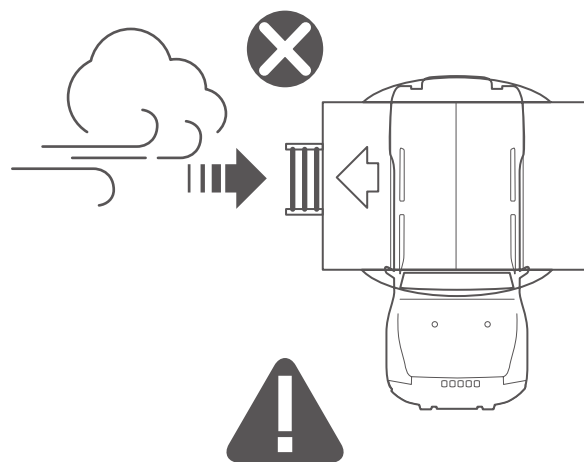
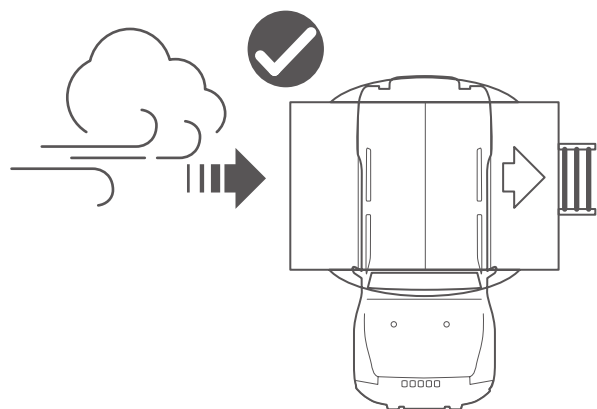



Atera TENTINO

Unpacking
Auspacken
Déballage

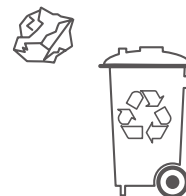
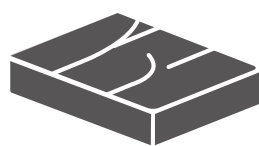
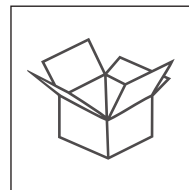

1.0



1x

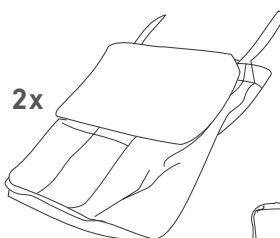

2x

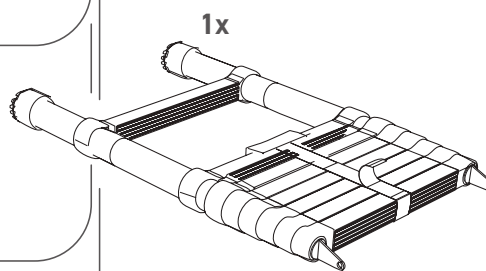

1x

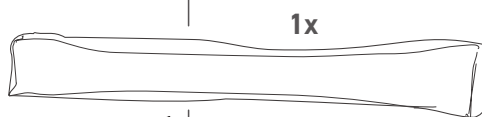

1x

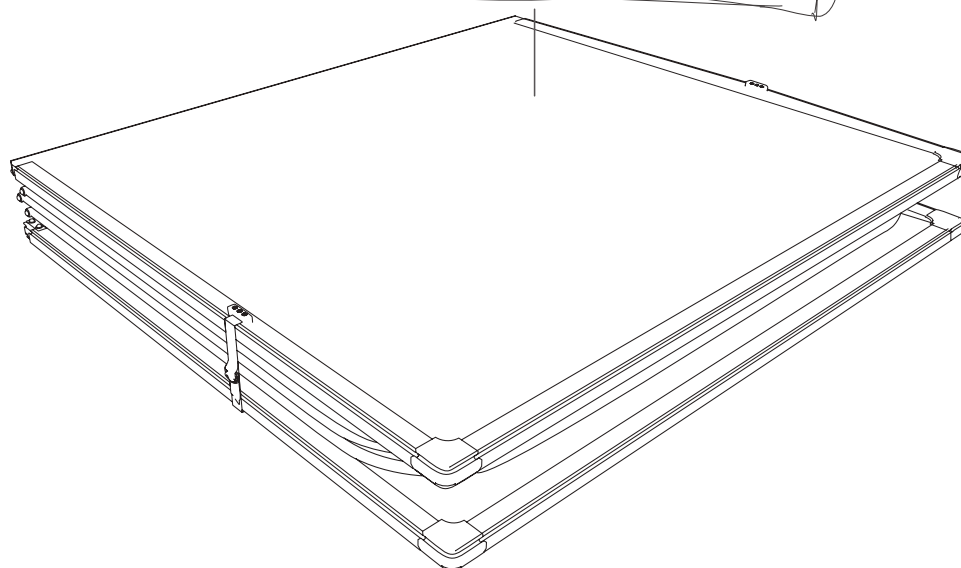



Atera TENTINO



Assembly of the ladder
Montage der Leiter
Visser l'échelle

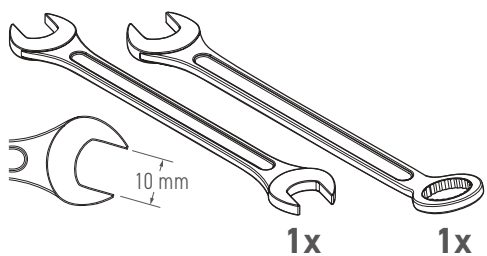

1x

1x

1.1

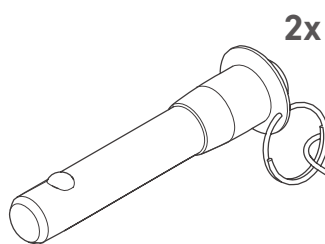

2x

Set A

4x

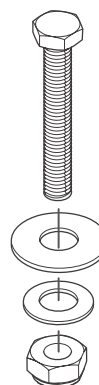

2x

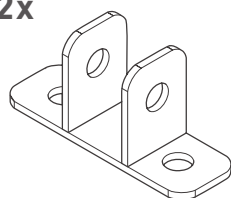

1x

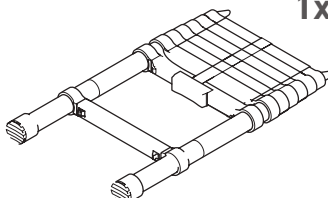



Atera TENTINO

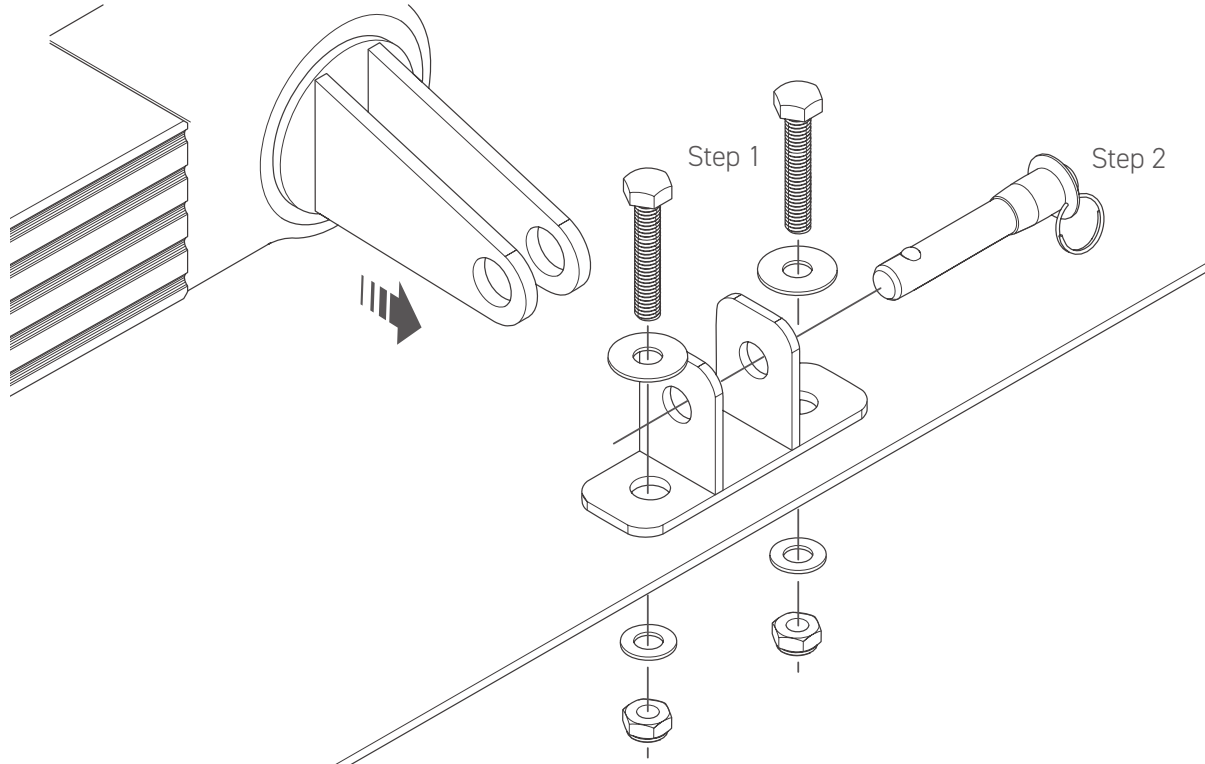

Step 2

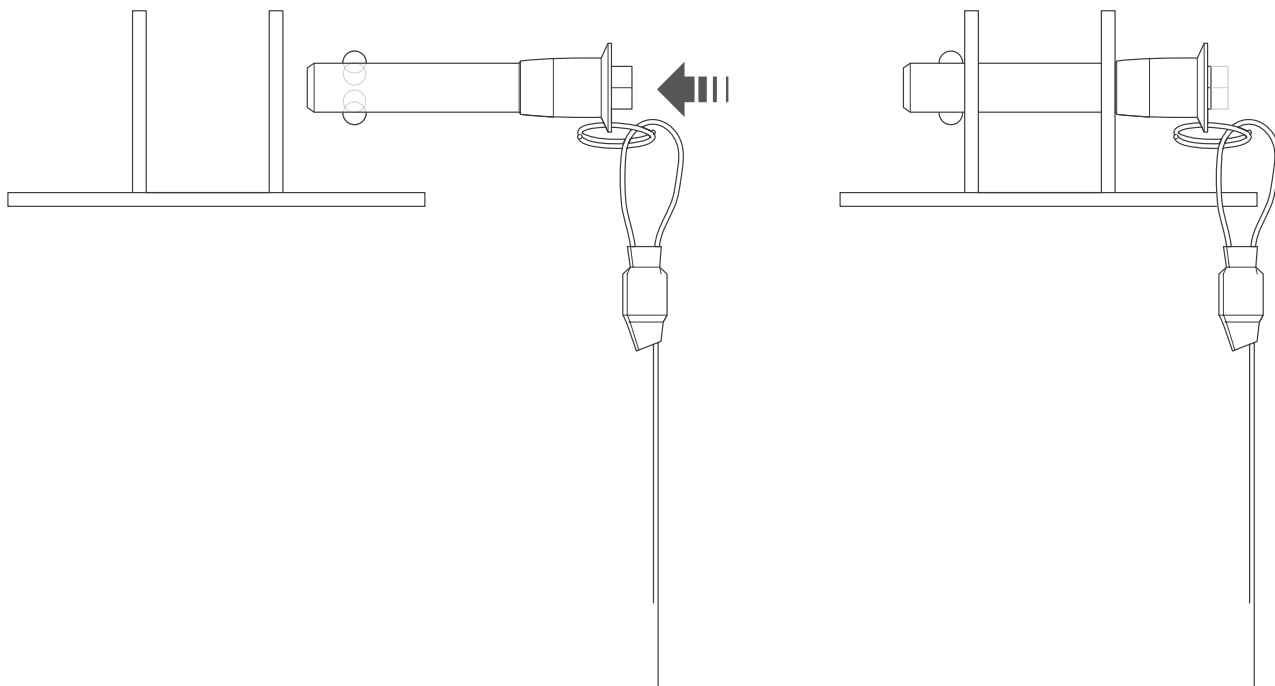



Atera TENTINO

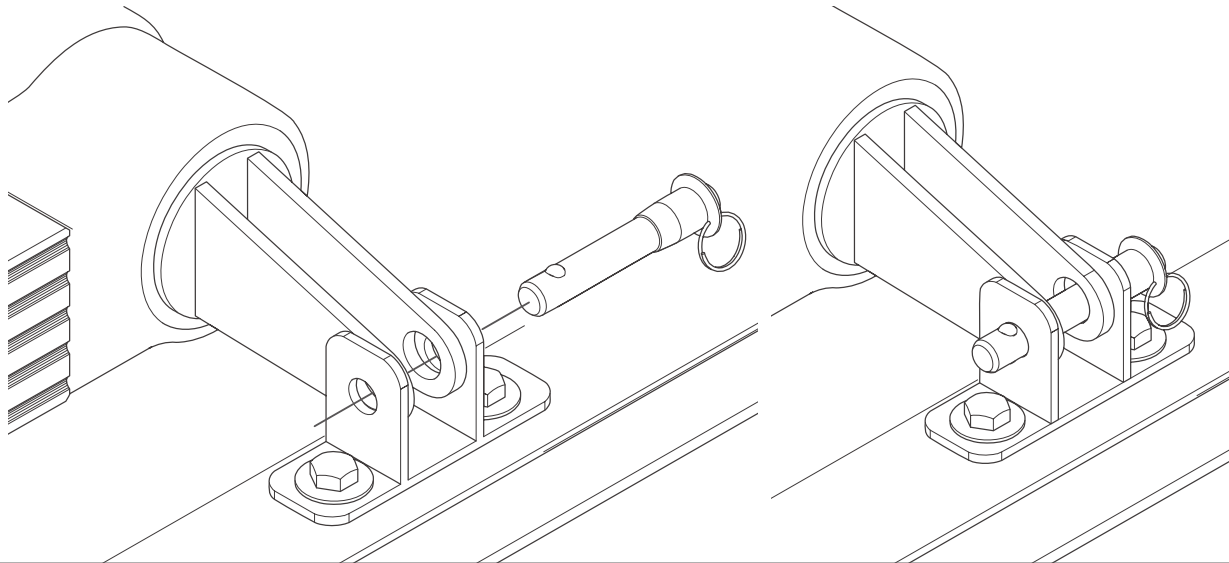

1.1

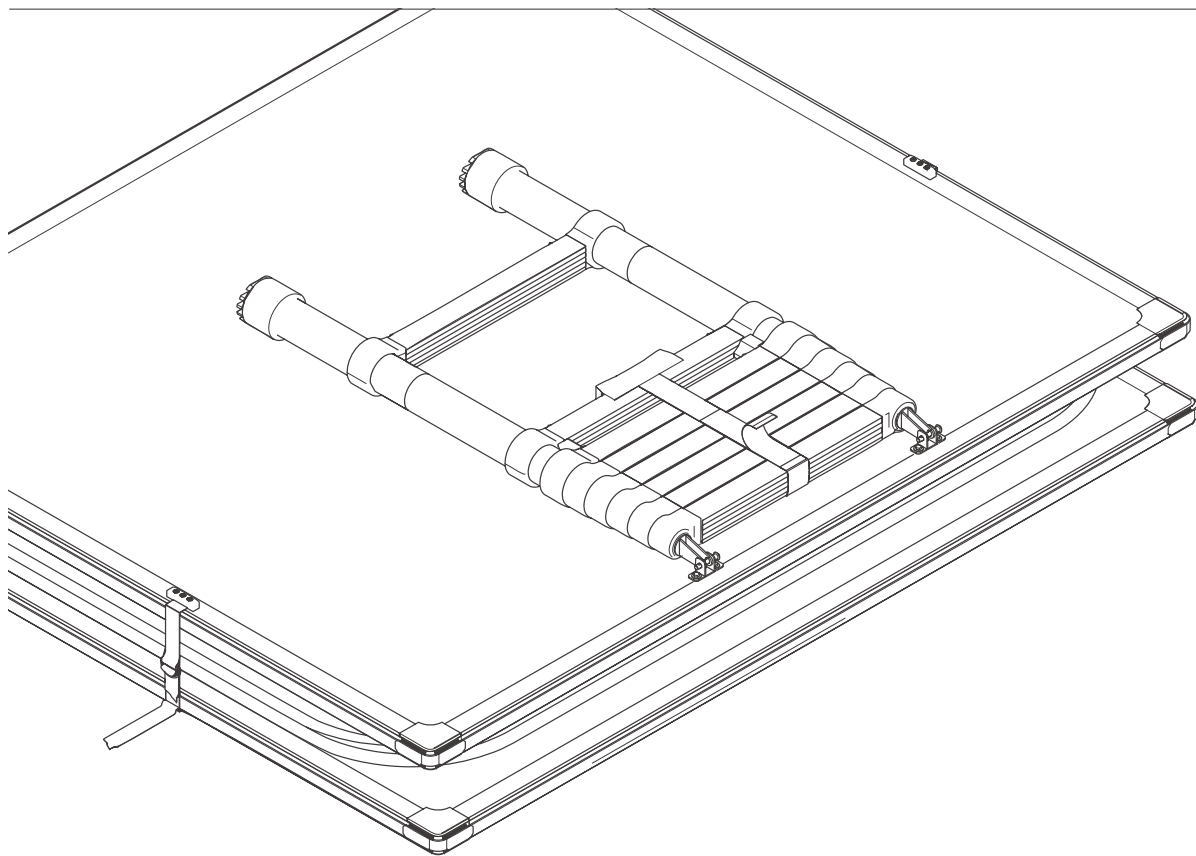



Atera TENTINO

Tarpaulin, fixing the roof sheet
Abdeckplane am Dachzelt fixieren
Bâche, fixation de la tôle du toit

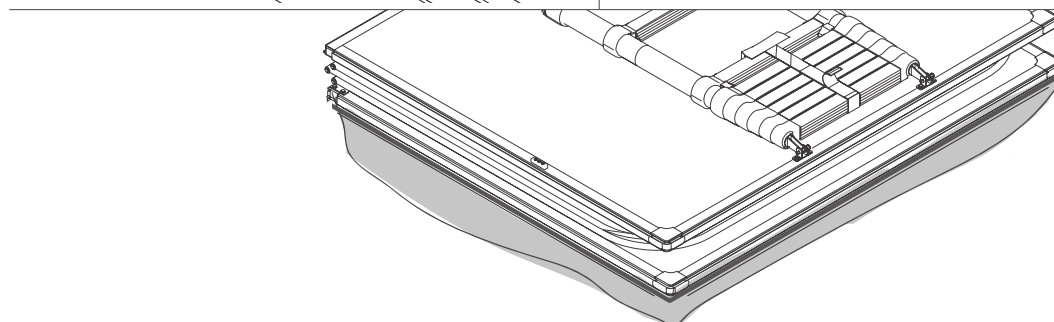
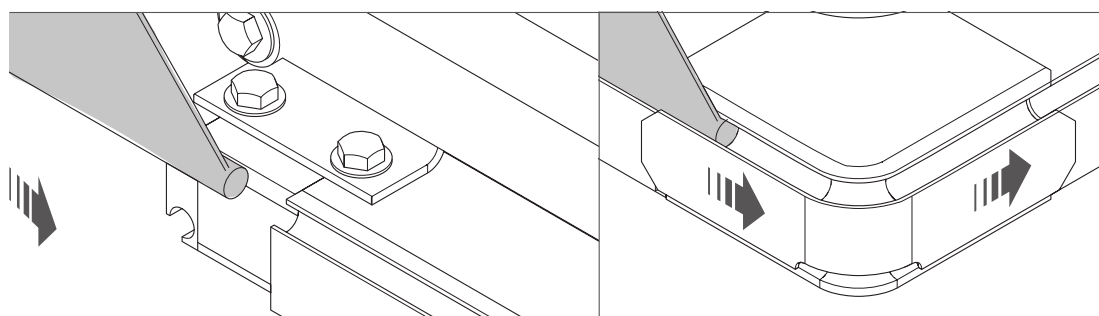
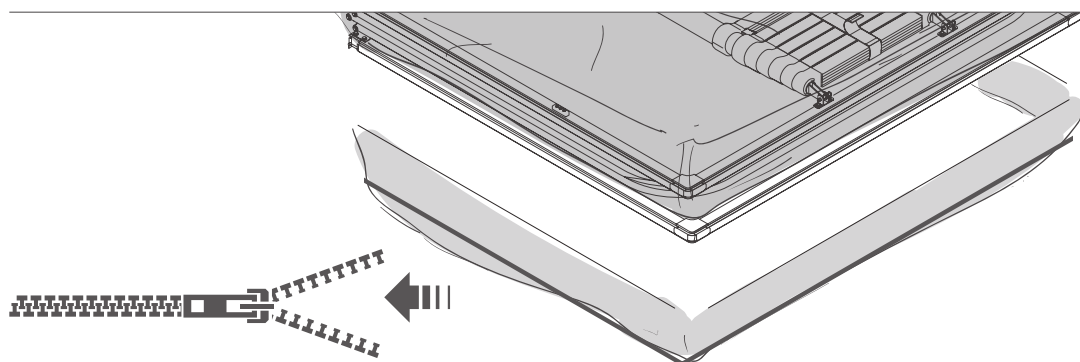
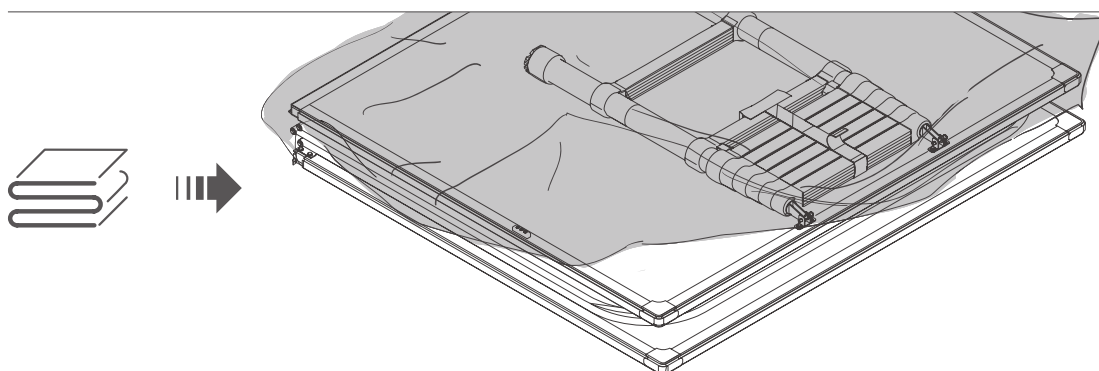
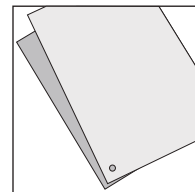



Atera TENTINO

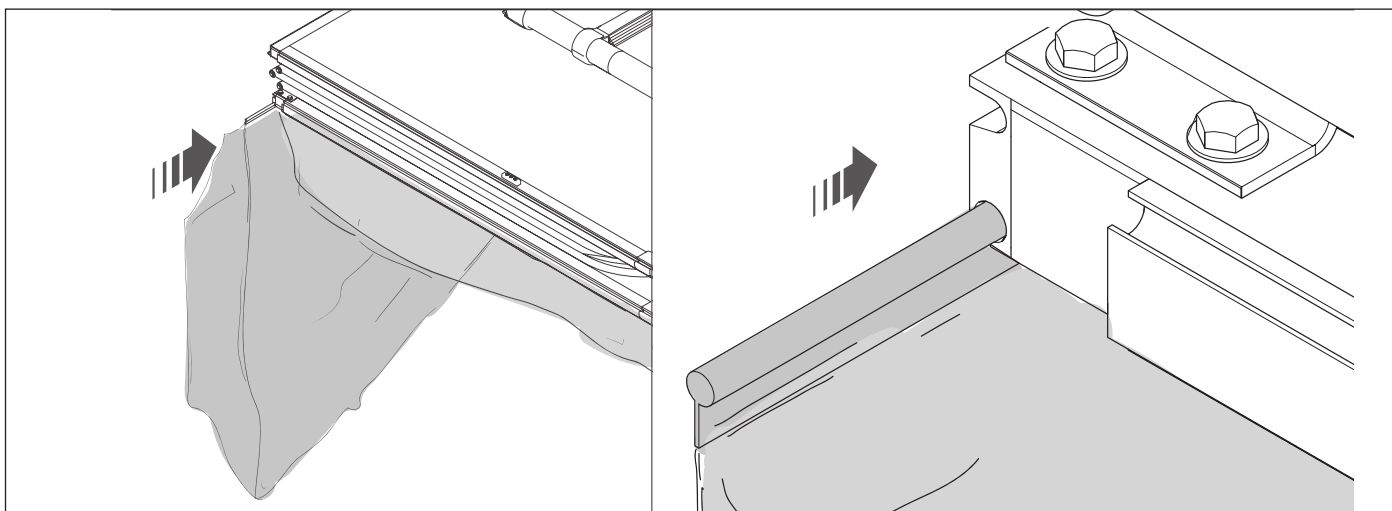

1.2

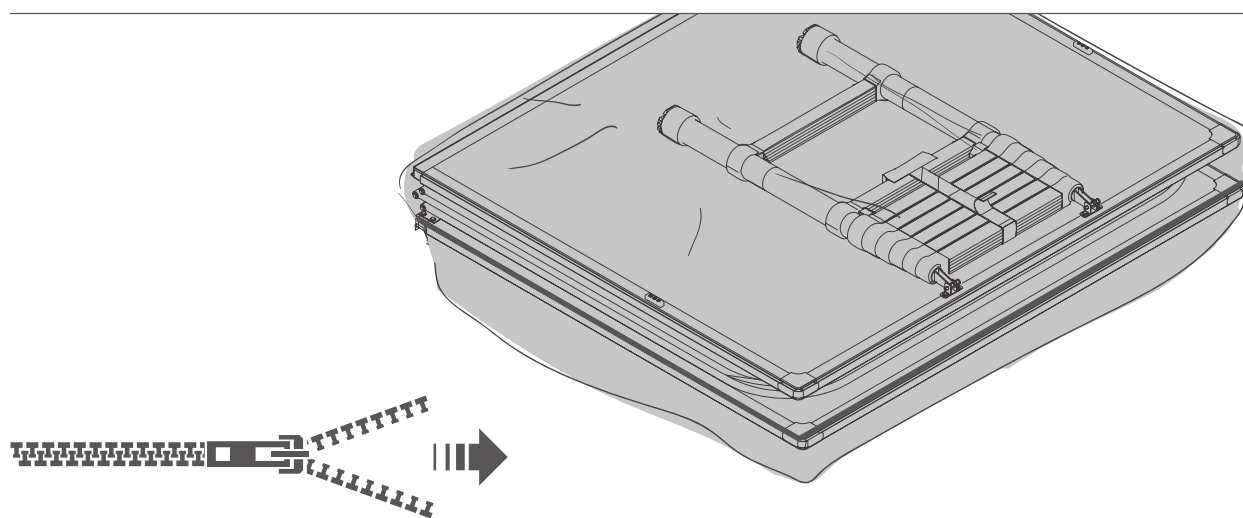
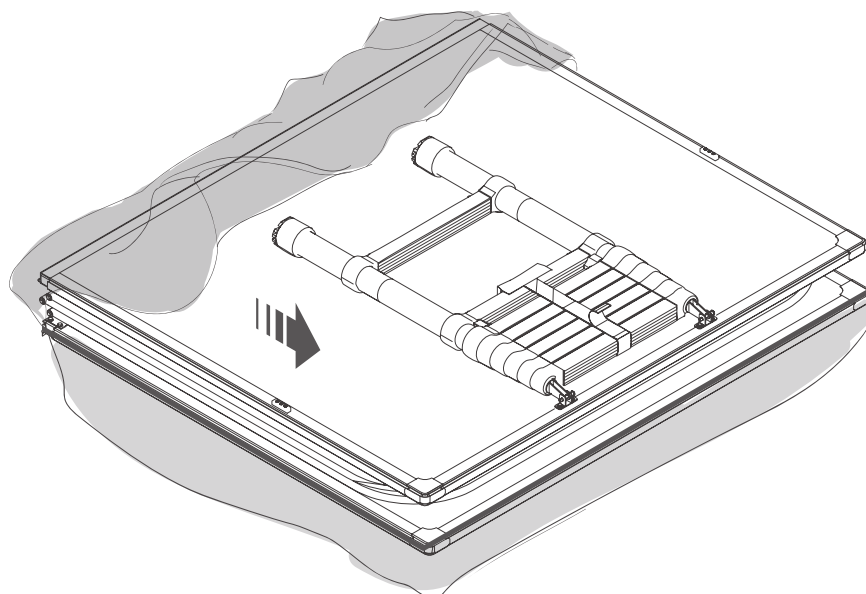



Atera TENTINO

Assembly tent on roof rack
 Montage Dachzelt auf Reling / Dachträger
 Montage de la tente sur la galerie de toit

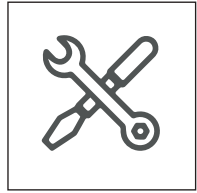

1x 13 mm wrench

4x [Bracket]

4x [Bracket]

8x [Bracket]

Set B
8x [Bolt, Washer, Nut]

1.3

The diagram illustrates the installation of the tent brackets onto a roof rack. It shows the required tools (a 13 mm wrench) and parts (brackets and hardware). The steps include: 1) Positioning the brackets on the roof rack rails. 2) A warning icon indicating that the brackets must be correctly aligned. 3) A top-down view of the car with brackets installed on both sides. 4) Close-up views of the brackets being secured to the roof rack rails using the provided hardware.





Atera TENTINO

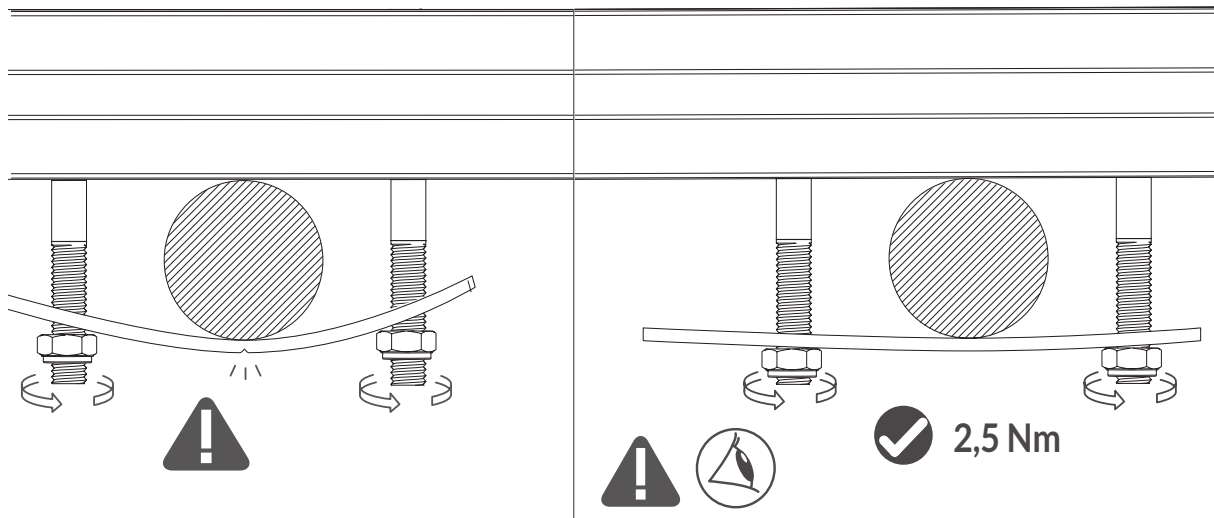
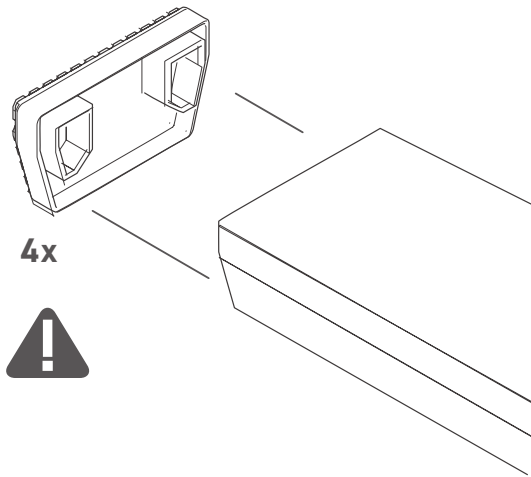

1.3

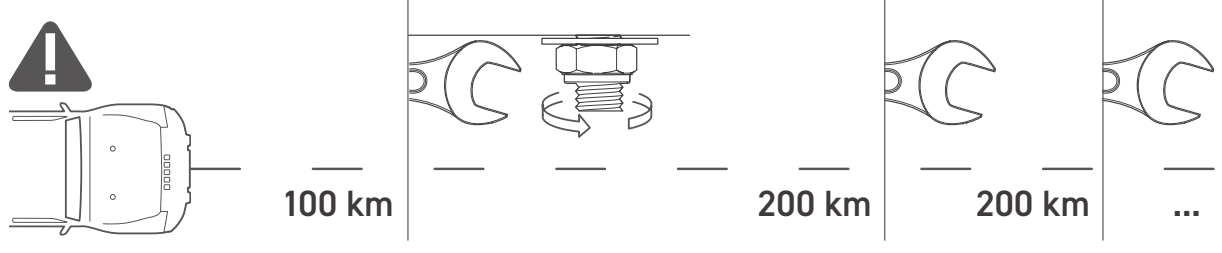
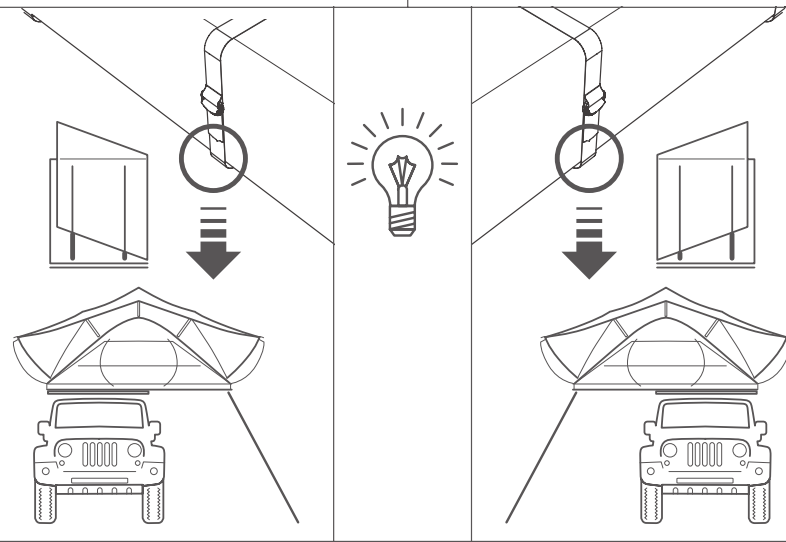



Atera TENTINO

Setting up first time after mounting
Der erste Aufbau nach erfolgreicher Montage
Première mise en place après le montage

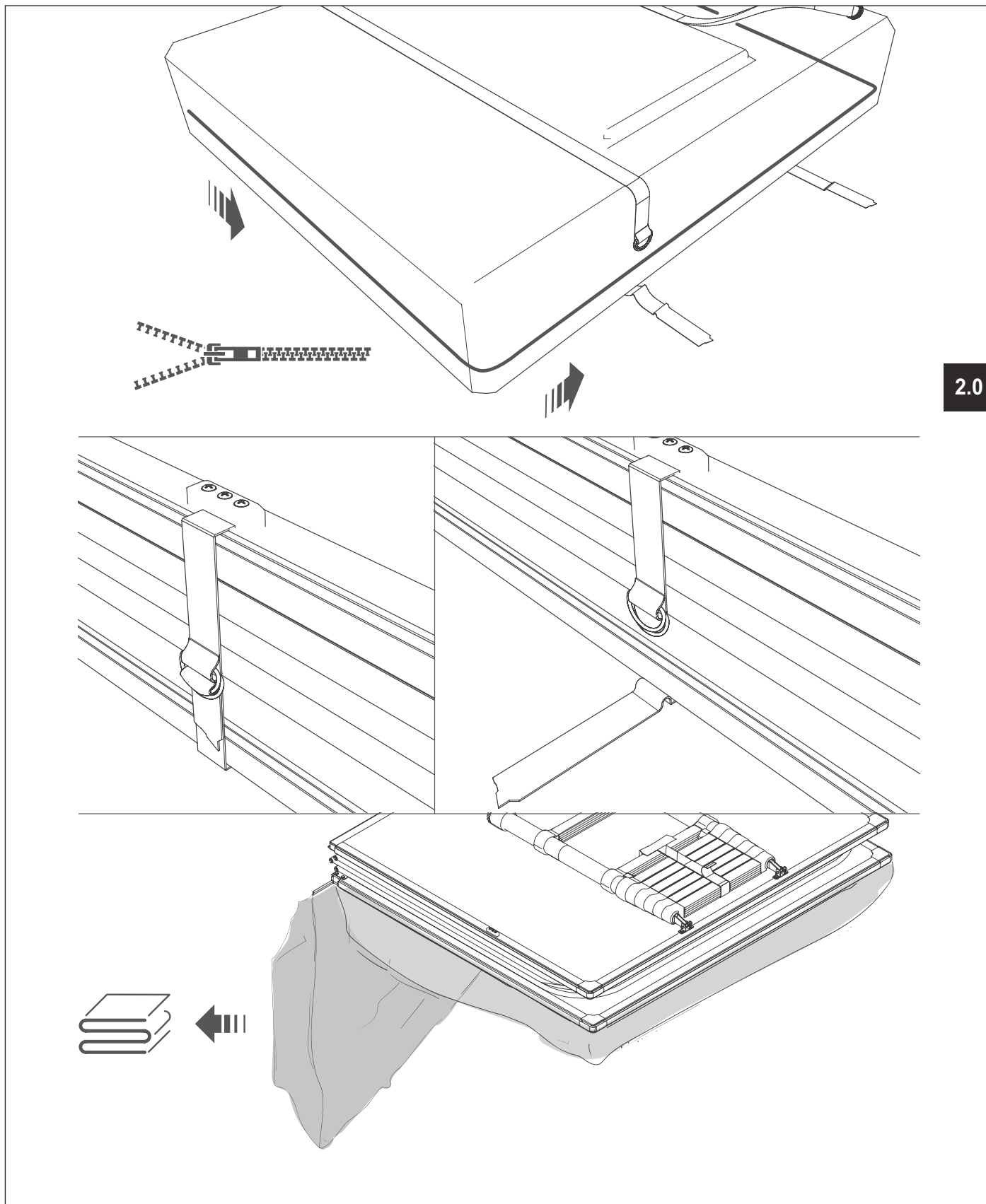
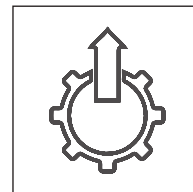

2.0





Atera TENTINO

2.1

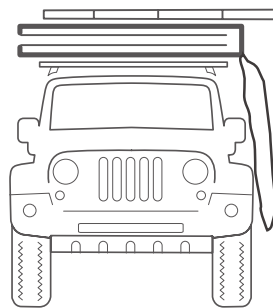
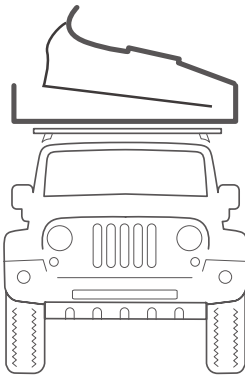
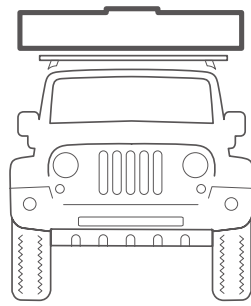

SNAP

SNAP

All-out





Atera TENTINO

Telescopic ladder
Teleskopleiter
Échelle télescopique

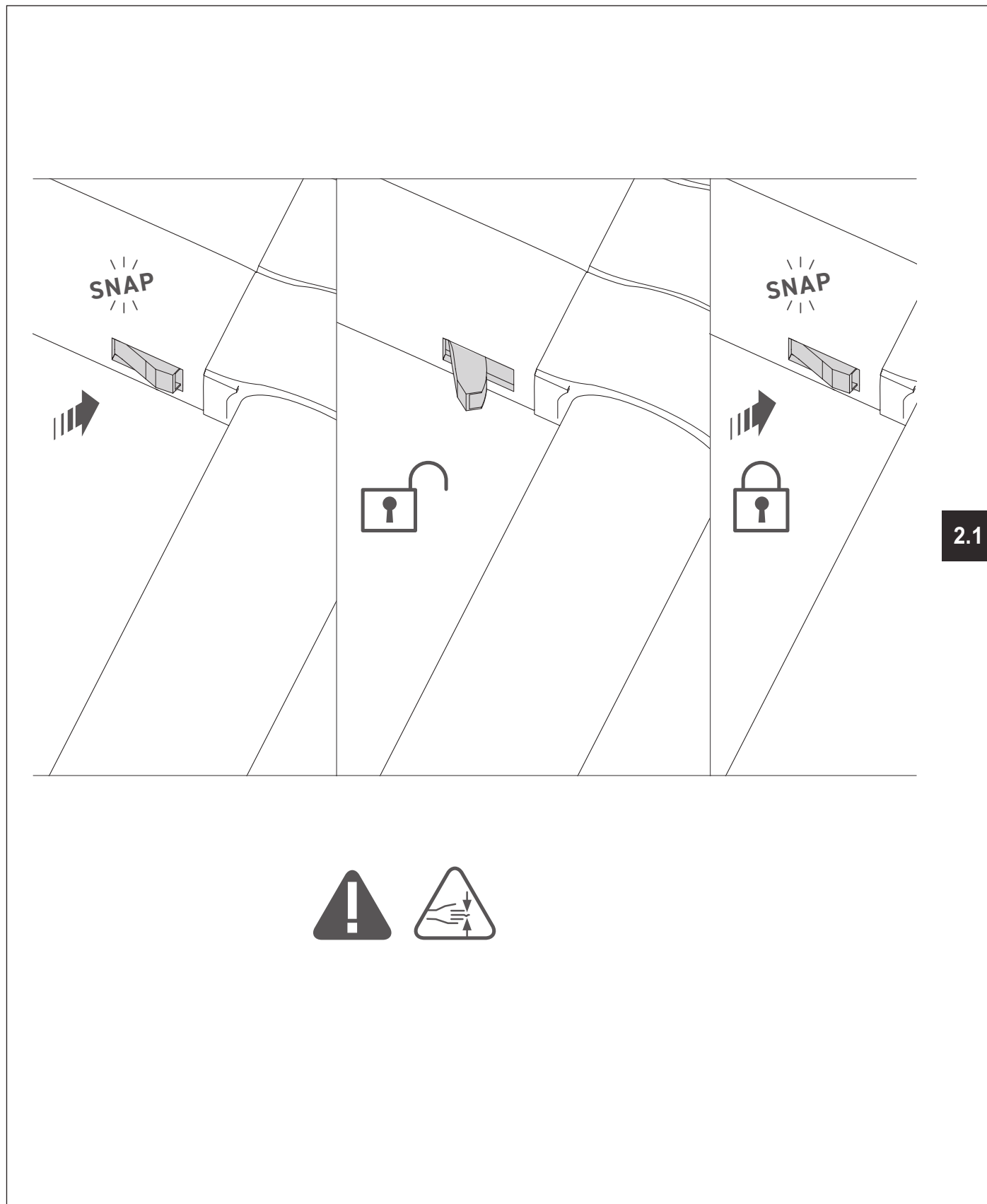
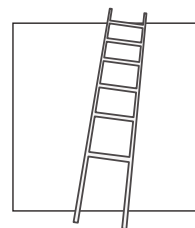



Atera TENTINO

2.1

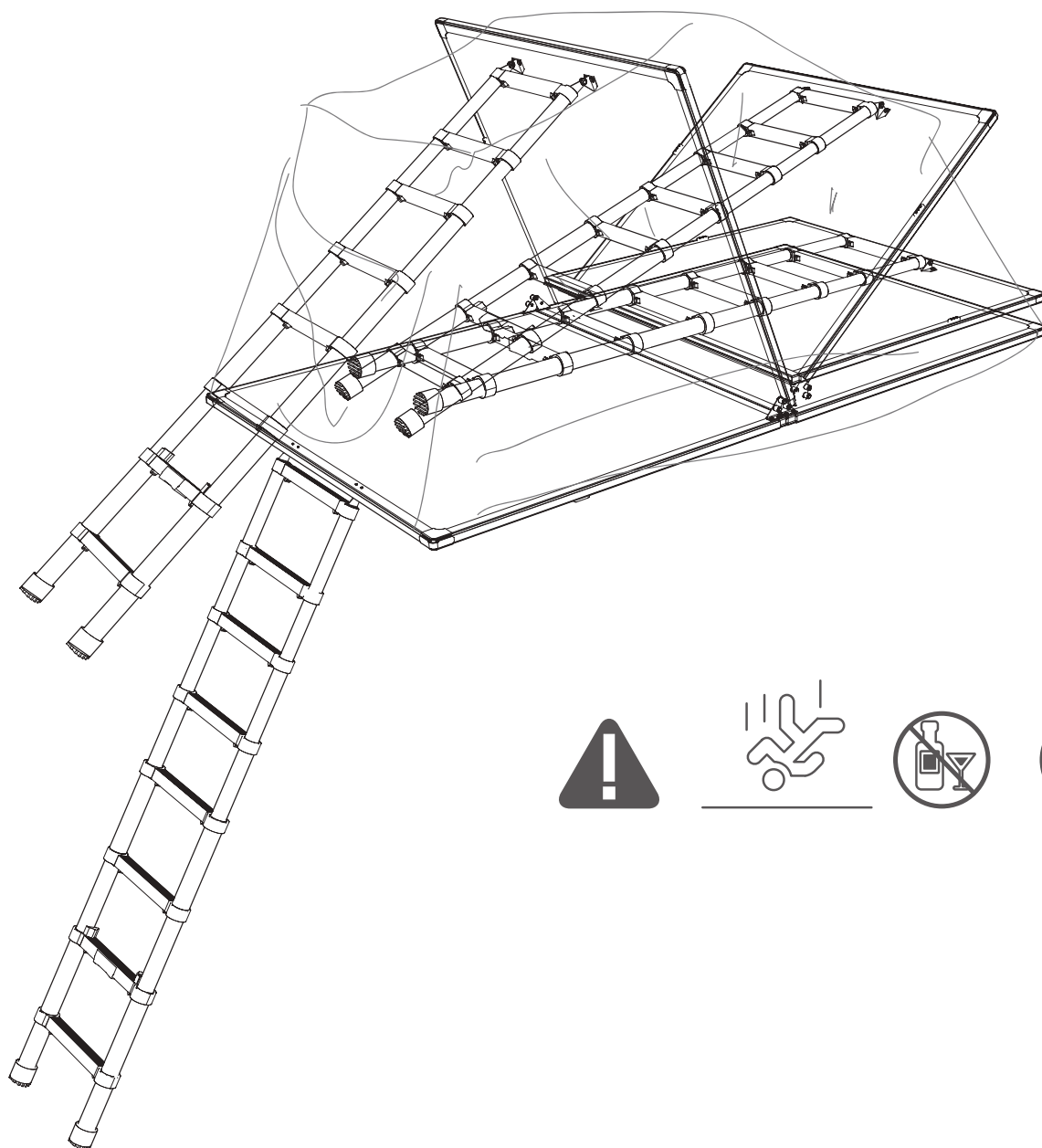



Atera TENTINO

Care instructions
Pflegehinweise
Instructions d'entretien

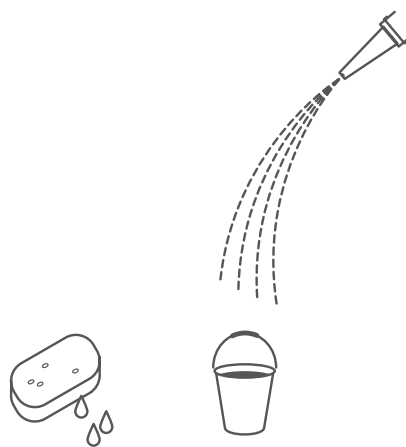
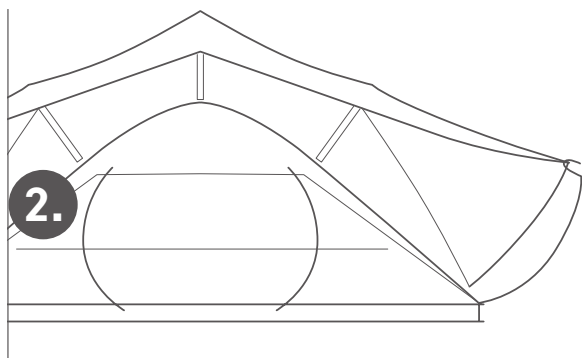
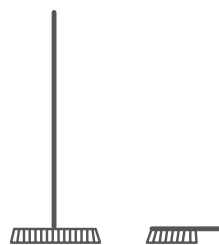
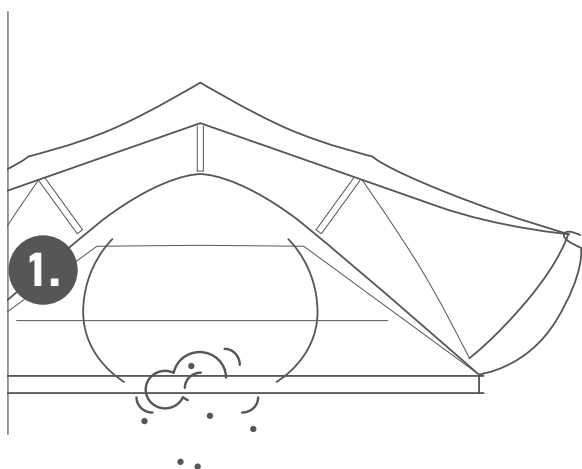
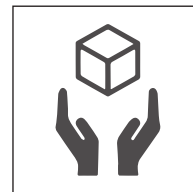

Silicone Spray

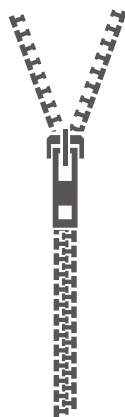
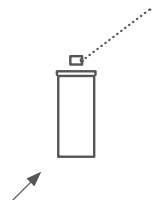



Atera TENTINO



Storage
Lagerung
Stockage

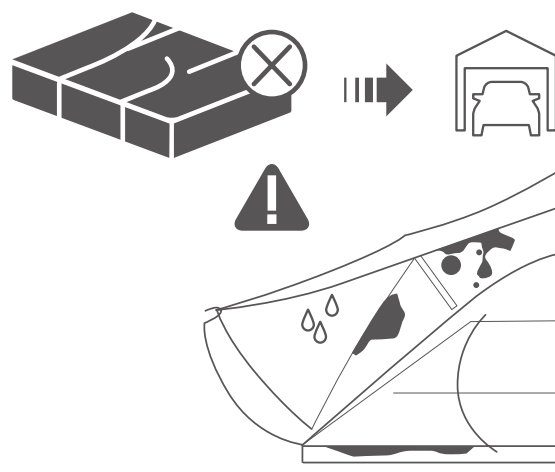
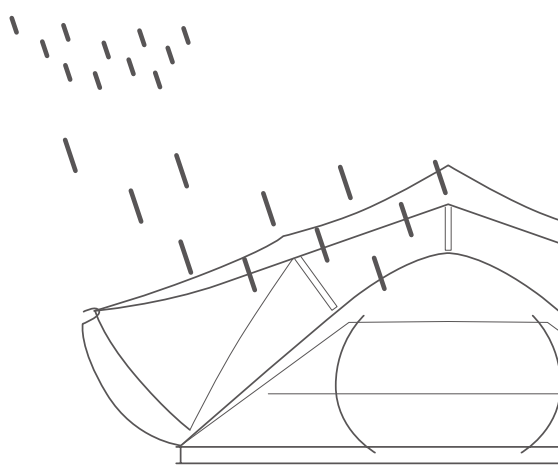
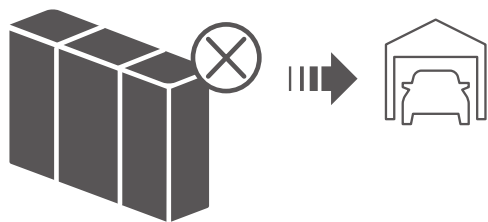
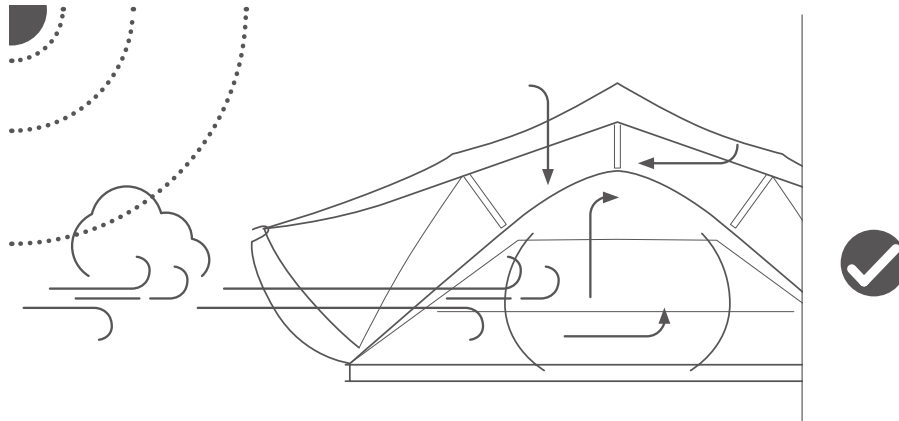

Atera TENTINO

EN

Safety instructions
Sicherheitshinweise
Consignes de sécurité



Safety Instructions

Please ensure that all Atera products are correctly and securely attached to your vehicle, trailer, etc. You are responsible for the mounting, attachment and safety of all Atera products to your vehicle, even if the mounting was done by a third party. Therefore, check the attachments in advance and at regular intervals the products for adjustment, wear and damage. Improper attachment could result in a car accident or serious and fatal injuries. Therefore, it is imperative that all instructions and precautions included or shipped with your Atera products be read and understood before installing and using the products. If the instructions and safety precautions are not understood and you are not thoroughly familiar with the installation in advance, the Atera product should be installed by a professional installer or a suitably qualified person.

The following points must be observed when the roof tent is folded on the vehicle:

Load securing

Roof tents, roof racks or roof platforms that are not installed correctly can come loose while driving and cause serious accidents and injuries. Therefore, follow the enclosed instructions for installing, using and handling the roof tents, roof racks or roof platforms.

Before driving, make sure that the roof tent mounts, bolts and carrier means have been properly and securely fastened. For longer journeys, in rough terrain, the roof tent holders and screws must be checked at regular intervals - every two hours - and tightened accordingly.

Furthermore, before driving, it must be ensured that the roof tent has been completely and correctly closed. In the case of canopy roof tents, it must be checked whether the roof tent cover and the straps have been closed. In the case of hard-shell roof tents, it must be checked whether the closures have been correctly locked.

Speed and driving behavior

The speed of the vehicle must always be adapted to the load carried and the current driving conditions, such as road type, road quality, road condition, wind conditions, traffic intensity and applicable speed limits, as well as other traffic signs.

Under no circumstances should the speed exceed 130 km/h. The vehicle's handling and braking characteristics change and air resistance increases with speed and could exert too much force on the roof tent.

Please drive slowly over speed bumps - maximum speed 10 km/h.

Roof load

The permissible total weight of the respective vehicle must not be exceeded under any circumstances. The vehicle manufacturer's specifications on the maximum and dynamic roof load must be observed. The permissible roof load is not specified in the vehicle's registration certificate; it can only be found in the vehicle's operating instructions. Regardless of this, the car as a whole must not be overloaded, because overloading is dangerous and simply forbidden. This applies not only to the permissible total weight, but also to the maximum permissible roof load, because the roof load predominantly places a load on the rear axle.

After using your roof tent, always tighten the roof rack/check that it is firmly secured before driving off.

Maximum roof load: The total weight of the load that may be carried on the roof of the car (also depends on the roof rack/platform).

Dynamic roof load: This is how much weight can be placed on the roof of the car while driving.

Permissible total weight: The total weight of the vehicle with the load on the roof and in the vehicle.

Calculation of dynamic roof load: Weight of roof rack/roof platform + weight of roof tent + weight of payload = available roof load

Atera TENTINO

Mounting instructions

For your own safety, only use tested, e.g. GS-approved roof racks that are approved for use in conjunction with the vehicle. In order to avoid the generation of excessive lifting forces, the roof tent must be mounted parallel to the road line. Laterally, the roof tent must not protrude more than 40 cm beyond the marker lights. A maximum of 2.55 m is permitted for the overall width. To the front, the roof tent must not protrude beyond the roof of the vehicle at all and must not impair the field of vision under any circumstances.

The height of the respective vehicle can increase by up to 60 cm - depending on the roof rack and roof tent used. Therefore, always consider your adjusted vehicle height (incl. roof rack and roof tent) when entering garages, parking garages, general clearance heights, low-hanging branches, etc. The vehicle incl. roof tent must not exceed the maximum height of four meters.

If no special mounting position is specified in the corresponding mounting instructions, please maintain a minimum distance of 70 cm between the crossbars. Please note that any changes, such as additional drill holes on the mounting system or general structural changes to the roof tent are not permitted and the warranty claims are therefore exhausted.

In addition to the roof tent instructions, the installation instructions of the respective roof rack and the operating instructions of the respective vehicle should also be taken into account.

Car wash

When using a car wash, the roof tent and corresponding roof rack must be removed in advance.

General notes

A load on the roof affects the behavior of the vehicle. It changes the wind resistance considerably, the fuel and power consumption increases. Therefore, the roof tent and roof rack should be removed when not in use.

DE

Sicherheitshinweise

Bitte beachtet, dass alle Atera-Produkte korrekt und sicher an eurem Fahrzeug, Anhänger, etc. befestigt wurden. Ihr seid für die Montage, Befestigung und Sicherheit aller Atera-Produkte an eurem Fahrzeug verantwortlich, auch wenn die Montage durch eine dritte Person erfolgt ist. Überprüft daher vorab die Anbaugeräte und in regelmäßigen Abständen die Produkte auf ihre Einstellung, den Verschleiß und auf Beschädigungen. Eine unsachgemäße Befestigung könnte zu einem Autounfall oder zu schweren und tödlichen Verletzungen führen. Daher müssen zwingend vor der Installation und Verwendung der Produkte alle Anweisungen und Vorsichtsmaßnahmen, die in euren Atera-Produkten mitgeliefert oder verschickt werden, gelesen und verstanden werden. Falls die Anweisungen und Sicherheitshinweise nicht verstanden wurden und ihr mit der Installation vorab nicht gründlich vertraut seid, sollte das Atera-Produkt von einem professionellen Installateur oder einer entsprechend qualifizierten Person installiert werden.

Folgende Punkte müssen beim zusammengeklappten Dachzelt auf dem Fahrzeug beachtet werden:

Ladungssicherung

Nicht korrekt montierte Dachzelte, Dachträger oder Dachplattformen können sich während der Fahrt lösen und schwere Unfälle und Verletzungen verursachen. Befolgt daher die beigegefügte Anweisungen zur Installation, Verwendung und Handhabung der Dachzelte, Dachträger oder Dachplattformen.

Vor der Fahrt muss sichergestellt werden, dass die Dachzelthalterungen, Schrauben und Trägermittel korrekt und sicher befestigt wurden. Bei längeren Fahrten, in unwegsamem Gelände müssen in regelmäßigen Abständen – alle zwei Stunden – die Dachzelthalterungen und Schrauben geprüft und entsprechend nachgezogen werden.

Des Weiteren muss vor der Fahrt sichergestellt werden, dass das Dachzelt vollständig und korrekt verschlossen wurde. Bei Kapp-Dachzelten muss geprüft werden, ob die Dachzeltplane und die Gurte verschlossen wurden. Bei Hartschalen-Dachzelte muss geprüft werden, ob die Verschlüsse korrekt verriegelt wurden.

Geschwindigkeit und Fahrverhalten

Die Geschwindigkeit des Fahrzeuges muss immer an die beförderte Last und die aktuellen Fahrbedingungen angepasst werden, wie z.B. Straßentyp, Straßenqualität, -beschaffenheit, Windverhältnisse, Verkehrsintensität und geltende Geschwindigkeitsbegrenzungen sowie sonstige Verkehrsregeln. **Die Geschwindigkeit darf auf keinen Fall 130 km/h überschreiten.** Die Fahreigenschaften und das Bremsverhalten des Fahrzeugs verändern sich und der Luftwiderstand nimmt mit der Geschwindigkeit zu und könnte zu viel Kraft auf das Dachzelt ausüben. Bitte langsam über Bodenschwellen fahren – Höchstgeschwindigkeit 10 km/h.

Atera TENTINO

Dachlast

Das zulässige Gesamtgewicht des jeweiligen Fahrzeuges darf auf keinen Fall überschritten werden. Die Angaben des Fahrzeugherstellers zur maximalen und dynamischen Dachlast sind zu beachten. Die zulässige Dachlast wird in der Zulassungsbescheinigung des Fahrzeugs nicht angegeben, sie ist nur in der Betriebsanleitung des Fahrzeugs zu finden. Unabhängig davon darf das Auto insgesamt nicht überladen werden, denn eine Überladung ist gefährlich und schlichtweg verboten. Das gilt nicht nur für das zulässige Gesamtgewicht, sondern auch für die maximal zulässige Dachlast, denn die Dachlast belastet zum überwiegenden Teil die Hinterachse.

Dachträger nach jeder Nutzung eines Dachzeltes vor Fahrtantritt nachziehen/ auf festen Sitz überprüfen.

Maximale Dachlast: So viel Gewicht darf insgesamt an Ladung auf das Autodach (ist auch vom Dachträger / der Plattform abhängig).

Dynamische Dachlast: So viel Gewicht darf während der Fahrt auf das Autodach.

Zulässiges Gesamtgewicht: So viel darf das Fahrzeug mit Zuladung auf dem Dach und im Fahrzeug insgesamt wiegen.

Berechnung der dynamischen Dachlast: Gewicht des Dachträgers/Dachplattform + Gewicht des Dachzeltes + Gewicht der Nutzlast = verfügbare Dachlast

Montagehinweise

Zur eigenen Sicherheit sollten nur geprüfte, z.B. GS-geprüfte Dachträger verwendet werden, die für die Verwendung in Verbindung mit dem Fahrzeug zugelassen sind. Um die Entstehung übermäßiger Hebekräfte zu vermeiden, muss das Dachzelt parallel zur Straßenlinie montiert werden. Seitlich darf das Dachzelt nicht weiter als 40 cm über die Begrenzungsleuchten hinausstehen. Bei der Gesamtbreite sind höchstens 2,55 m erlaubt. Nach vorne darf das Dachzelt gar nicht über das Fahrzeugdach hinausragen und darf das Sichtfeld unter keinen Umständen beeinträchtigen.

Die Höhe des jeweiligen Fahrzeuges kann sich um bis zu 60 cm erhöhen – abhängig vom verwendeten Dachträger und Dachzelt. Daher berücksichtigt stets eure angepasste Fahrzeughöhe (inkl. Dachträger und Dachzelt) bei Garageneinfahren, Parkhäusern, generelle Durchfahrtshöhen, tiefhängende Äste, usw. Das Fahrzeug inkl. Dachzelt darf die maximale Höhe von vier Metern nicht überschreiten.

Ist in der entsprechenden Montageanleitung keine besondere Montageposition angegeben, haltet bitte einen Mindestabstand von 70 cm zwischen den Querträgern ein. Bitte beachtet, dass jegliche Änderungen, wie z. B. zusätzliche Bohrlöcher am Befestigungssystem oder generelle bauliche Veränderungen am Dachzelt nicht zulässig sind und die Garantieansprüche somit erschlossen sind.

Zusätzlich zur Dachzelanleitung sollten auch die Montageanleitungen des jeweiligen Dachträgers und die Bedienungsanleitung des jeweiligen Fahrzeuges berücksichtigt werden.

Waschanlage

Bei der Nutzung einer Autowaschanlage muss vorab das Dachzelt und entsprechende Dachträger entfernt werden.

Generelle Hinweise

Eine Ladung auf dem Dach beeinflusst das Verhalten des Fahrzeuges. Es verändert sich der Windwiderstand erheblich, der Kraftstoff- und Stromverbrauch steigt. Daher sollte das Dachzelt und Dachträger bei Nichtgebrauch abgenommen werden.

Consignes de sécurité

Veillez à ce que tous les produits Atera soient correctement et solidement fixés à votre véhicule, remorque, etc. Vous êtes responsables du montage, de la fixation et de la sécurité de tous les produits Atera sur votre véhicule, même si le montage a été effectué par une tierce partie. Il convient donc de vérifier les pièces jointes à l'avance et à intervalles réguliers les produits pour vérifier s'ils sont ajustés, usés ou endommagés. Une mauvaise fixation peut entraîner un accident ou des blessures graves, voire mortelles. Par conséquent, il est impératif de respecter toutes les instructions et précautions incluses ou prises dans le cadre de l'utilisation de cet accessoire. Les instructions fournies avec les produits Atera doivent être lues et comprises avant l'installation et l'utilisation des produits. Si les instructions et les précautions de sécurité n'ont pas été comprises et vous n'êtes pas complètement familiarisé avec ce produit, il doit être installé par un installateur professionnel ou une personne dûment qualifiée.

Les points suivants doivent être respectés lorsque la tente de toit est repliée sur le véhicule:

Sécurisation de la charge

Les tentes de toit, les barres de toit ou les plates-formes de toit qui ne sont pas installées correctement peuvent se détacher pendant la conduite et peuvent provoquer des accidents et des blessures graves. Il convient donc de suivre les instructions ci-jointes pour l'installation, l'utilisation, l'entretien et la manipulation des tentes de toit, des galeries de toit ou des plates-formes de toit.

Avant de prendre la route, assurez-vous que les supports de la tente de toit, les boulons et les supports sont correctement et solidement fixés. Pour les trajets plus longs, en terrain accidenté, les supports de la tente de toit et les vis doivent être vérifiés à intervalles réguliers - toutes les deux heures - et resserrés en conséquence.

En outre, avant de prendre la route, il faut s'assurer que la tente de toit a été complètement et correctement installée et fermée. Dans le cas des tentes à toit en forme d'avent, il faut vérifier que la toile de tente et les sangles sont bien fermées. Dans le cas des tentes à toit rigide, il convient de vérifier si les fermetures ont été correctement verrouillées.

Vitesse et comportement au volant

La vitesse du véhicule doit toujours être adaptée à la charge transportée et aux conditions de conduite actuelles, tels que le type de route, la qualité de la route, l'état de la route, les conditions de vent, l'intensité du trafic et la vitesse applicable. **La vitesse ne doit en aucun cas dépasser 130 km/h.** Les caractéristiques de maniabilité et de freinage du véhicule changent et la résistance à l'air augmente avec la vitesse et pourrait être plus importante que la résistance à l'air et ainsi exercer une force trop importante sur la tente de toit. Veuillez rouler lentement sur les dos d'âne - vitesse maximale de 10 km/h.

Charge de la toiture

Le poids total autorisé du véhicule ne doit en aucun cas être dépassé. Les spécifications du constructeur du véhicule concernant la charge maximale et dynamique du toit doivent être respectées. Il convient de respecter les indications du constructeur du véhicule concernant la charge maximale et dynamique du toit. La charge de toit autorisée n'est pas spécifiée dans le certificat d'immatriculation du véhicule ; elle ne figure que dans le certificat d'immatriculation du véhicule et les instructions d'utilisation du véhicule. Quoi qu'il en soit, la voiture dans son ensemble ne doit pas être surchargée, car la surcharge est dangereuse et tout simplement interdite. Cela s'applique non seulement au poids total autorisé, mais également à la charge maximale autorisée sur le toit, car la charge sur le toit pèse principalement sur l'arrière de la voiture.

Après avoir utilisé votre tente de toit, resserrez toujours les barres de toit et vérifiez qu'elles sont bien fixées avant de partir.

Charge maximale sur le toit : Le poids total de la charge qui peut être transportée sur le toit de la voiture (dépend également de la taille de la voiture).
sur la galerie/plateforme de toit).

Charge dynamique du toit : Il s'agit du poids qui peut être placé sur le toit de la voiture pendant la conduite.

Poids total autorisé : Le poids total du véhicule avec la charge sur le toit et dans le véhicule.

Calcul de la charge dynamique du toit : Poids de la galerie/plate-forme de toit + poids de la tente de toit + poids de l'équipement de protection contre les intempéries.
charge utile = charge de toit disponible



Atera TENTINO

Instructions de montage

Pour votre propre sécurité, n'utilisez que des barres de toit testées, par exemple homologuées GS, et dont l'utilisation est autorisée en association avec des barres de toit homologuées GS.

avec le véhicule. Afin d'éviter la génération de forces de levage excessives, la tente de toit doit être montée parallèlement à la ligne de route. Latéralement, la tente de toit ne doit pas dépasser de plus de 40 cm les feux de position. Un maximum de 2,55 m est autorisé pour la largeur totale. À l'avant, la tente de toit ne doit pas dépasser du tout le toit du véhicule et ne doit en aucun cas gêner le champ de vision.

La hauteur du véhicule peut augmenter jusqu'à 60 cm, en fonction de la galerie et du toit et de la tente utilisée. Par conséquent, tenez toujours compte de la hauteur ajustée de votre véhicule (y compris les barres de toit et la tente de toit) lorsque vous utilisez la tente de toit, l'entrée dans les garages, les parkings, les hauteurs de passage générales, les branches basses, etc. La tente de toit avec le véhicule ne doit pas dépasser la hauteur maximale de quatre mètres.

Si aucune position de montage particulière n'est spécifiée dans les instructions de montage correspondantes, veuillez maintenir une position de montage spéciale - distance minimale de 70 cm entre les barres transversales. Veuillez noter que toute modification, telle que l'ajout d'un perçage supplémentaire est interdite.

Il est interdit de percer des trous dans le système de montage ou d'apporter des modifications structurelles générales à la tente de toit. Les recours en garantie seraient donc épuisés.

En plus des instructions relatives à la tente de toit, les instructions d'installation de la galerie de toit et du système de fixation de la tente de toit doivent être respectées.

Les instructions d'utilisation du véhicule concerné doivent également être prises en compte.

Lavage de voitures

Lors de l'utilisation d'une station de lavage, la tente de toit et la galerie de toit correspondante doivent être retirées au préalable.

Notes générales

Une charge sur le toit affecte le comportement du véhicule. Elle modifie considérablement la résistance au vent, la consommation de carburant et les émissions de gaz à effet de serre et la consommation d'énergie augmente. Par conséquent, la tente et la galerie de toit doivent être retirées lorsqu'elles ne sont pas utilisées.



Atera TENTINO



Atera

Atera GmbH
Im Herrach 1
D-88299 Leutkirch
Internet: www.atera.de



© ATERA GmbH
Ref.-Nr.: 082 299_000000000000_096498229900
Stand/State/État: 22/03/2024 - Rev 00 Ver 00

